

Parts List			
ITEM	QTY	STOCK NUMBER	DESCRIPTION
1	1	13-XXXX	A-1024 MANHOLE COVER ASSEMBLY
2	1	18-XXXX	CONCRETE RISER
3	2	18-XXXX	BASKET STRAINER
4	2	18-XXXX	BELL
5	6	18-XXXX	BOWL
6	2	20-6274	BASE - VV - 810 MIDDLE
7	1	20-6278	BASE - VV - 810
8	1	24-XXXX	TOP SLAB - VV - 810 - H20
9	4	25-6530	STAND: 4" PIPE SUPPORT S89 FLG
10	1	25-XXXX	LADDER - 12.5ft
11	2	30-XXXX	MOTOR - 256TPH - 20HP
12	2	31-XXXX	SOLE PLATE - DISCHARGE HEAD
13	2	31-XXXX	DISCHARGE HEAD
14	2	32-XXXX	MOTOR SHAFT
15	1	40-5089	NIPPLE - GALV - 2in SCH40 X CLOSE
16	1	40-6245	NIPPLE - GALV - 2in SCH40 X 6in
17	2	40-XXXX	COLUMN PIPE - 6in
18	1	41-5041	VALVE - BALL - 2in BRASS - 1-4 TURN
19	2	41-6564	HANDWHEEL - 8in
20	2	41-6567	VALVE - PLUG - 6in - WITH OP NUT
21	2	41-6569	VALVE - SWING CHECK - 6in - 506A
22	1	41-XXXX	AIR RELEASE VALVE
23	2	42-XXXX	COUPLER - COLUMN PIPE
24	1	43-6135	KOR-N-SEAL - 12in CORE - 8in PIPE
25	1	44-XXXX	FLANGE - 6in WITH 2in TAP
26	1	45-5051	SPOOL - FLG X PE - 6in X 36in - DI
27	2	45-5280	SPOOL: 6"x18" DI FLG X FLG
28	2	45-6513	SPOOL - FLG X FLG - 6in X 6in - DI
29	1	45-XXXX	SPOOL - FLG X FLG - 6in X 23.75in - DI
30	1	46-6521	ELBOW - DI - 6in - 90 DEG - FLG X FLG
31	2	46-6525	TEE - DI - 6in - FLG X FLG
32	15	47-6547	GASKET - FLANGE - 6in X 1/8in
33	5	60-6117	MECH SWCH ENM-10 CABLE 43'

6" TO 8" FORCE MAIN - 200-1200 GALLONS PER MINUTE

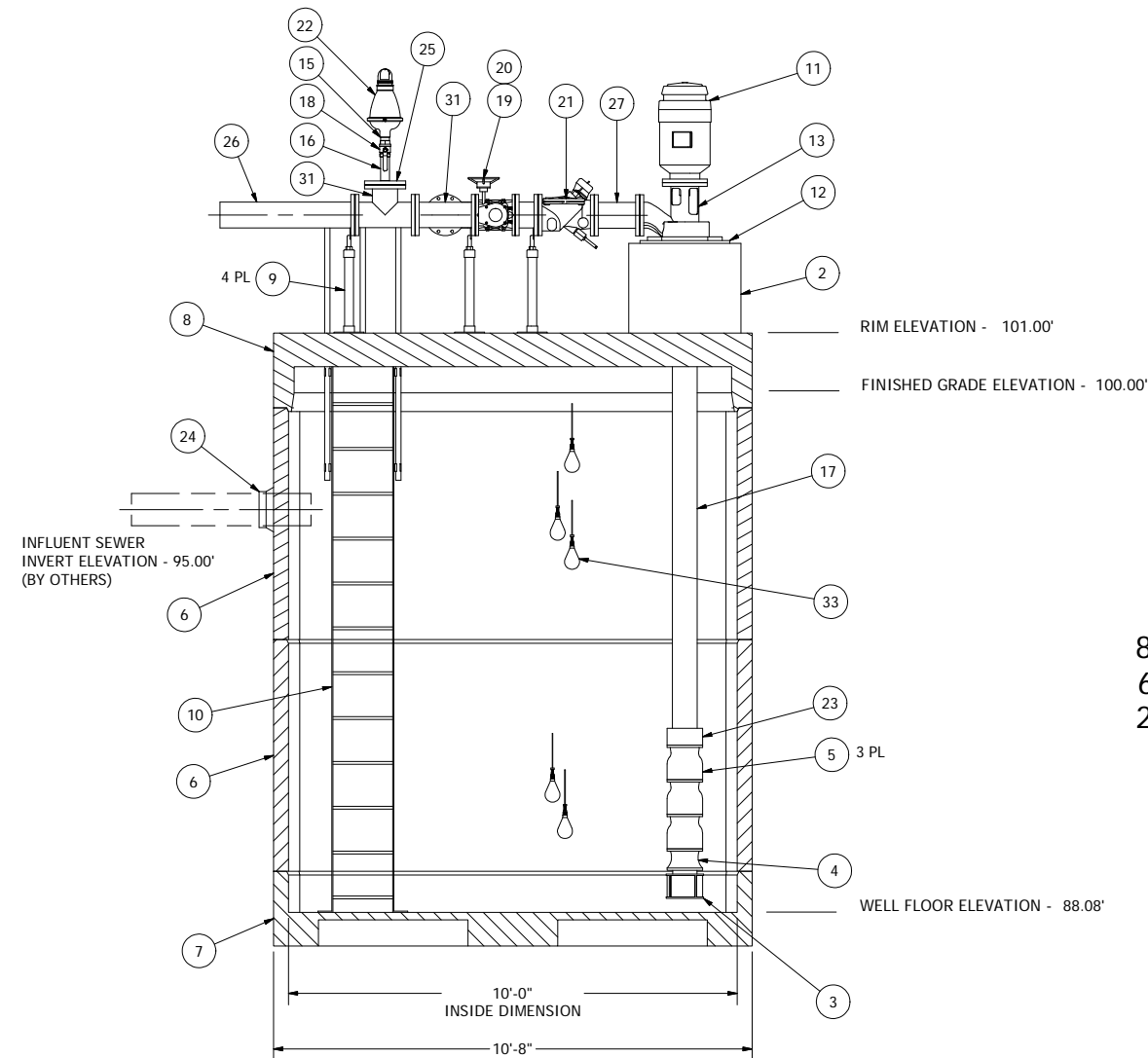
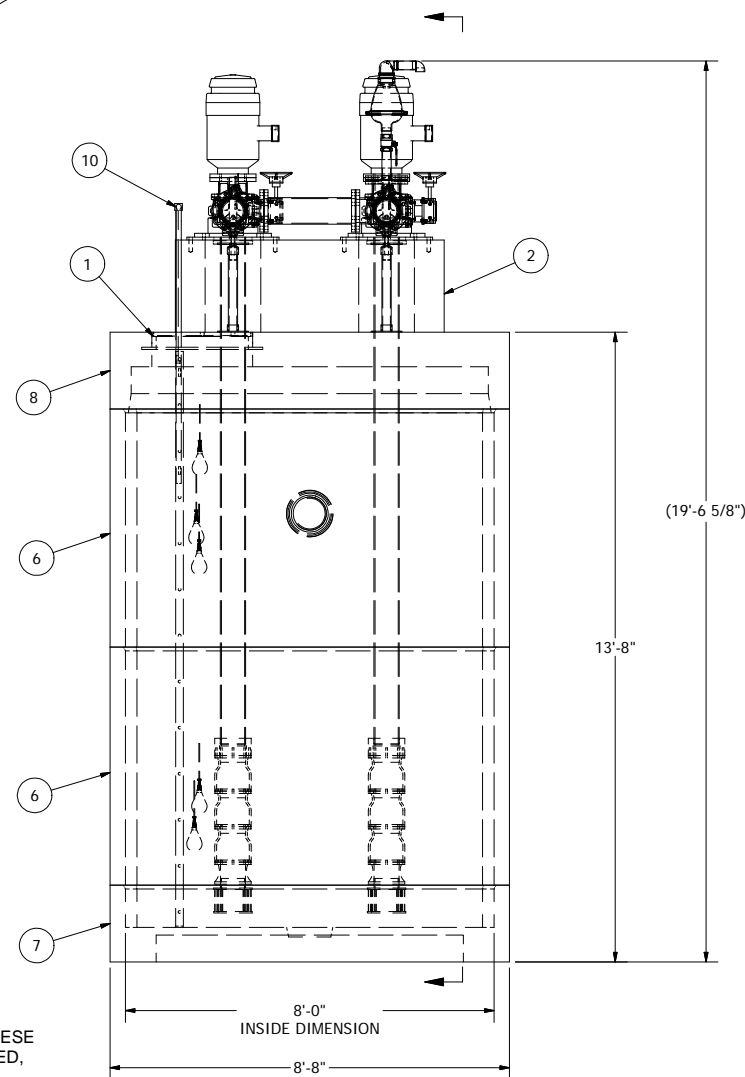

**8' X 10' WELL CHAMBER
6" DISCHARGE PIPING
20HP 3-STAGE TURBINE PUMPS**

NOTE: ALL DIMENSIONS AND ELEVATIONS SHOWN ARE NOMINAL DIMENSIONS. IT IS THE RESPONSIBILITY OF THE ON-SITE CONTRACTOR OR ROMTEC UTILITIES CUSTOMER (NOT ROMTEC UTILITIES) TO VERIFY THE ACCURACY OF ANY CRITICAL DIMENSIONS OR ELEVATIONS PRIOR TO SETTING OR INSTALLING ANY EQUIPMENT.

ALL MATERIALS SHOWN ON THIS SHEET WILL BE SUPPLIED BY ROMTEC UTILITIES AND DELIVERED TO THE SITE AFTER THE HOLE HAS BEEN EXCAVATED AND SHORED. THE CONTRACTOR SHALL SUPPLY A CRANE OF SUFFICIENT SIZE TO LOWER ALL THE CONCRETE PIECES INTO THE HOLE SAFELY. THE CONTRACTOR SHALL INSTALL THE WET WELL (AND VALVE VAULT AND METERING VAULT IF APPLICABLE). ROMTEC UTILITIES WILL PROVIDE A REPRESENTATIVE FOR TECHNICAL ASSISTANCE ON THE DAY OF INSTALLATION TO ANSWER ANY QUESTIONS THAT MAY ARISE. THE CONTRACTOR IS RESPONSIBLE FOR ALL PLUMBING AND ELECTRICAL CONNECTIONS AND INSTALLATION. ITEMS NOTED AS "BY OTHERS" WILL BE PROVIDED AND INSTALLED BY THE CONTRACTOR. ROMTEC UTILITIES WILL NOT INSTALL ANY OF THE COMPONENTS SHOWN ON THIS PAGE.

© 2009 ROMTEC INC. ALL RIGHTS RESERVED. THESE PLANS AND DRAWINGS MAY NOT BE REPRODUCED, ADAPTED, OR FURTHER DISTRIBUTED, AND NO COMPONENTS MAY BE CONSTRUCTED FROM THESE PLANS, WITHOUT WRITTEN PERMISSION OF ROMTEC, INC.

DATE	DESCRIPTION	REV
04/09/09	COMPONENT DRAWING	1

COMPONENT DRAWING

ROMTEC UTILITIES
18240 NORTH BANK ROAD
ROSEBURG, OREGON 97470
(541) 496-9678
FAX (541) 496-0804

ROMTEC Utilities, Inc.
**SMALL FLOW
LINE SHAFT TURBINE SYSTEM**

SHEET
1 OF 1
JOB NUMBER
**RMTC
0000**