

**3" TO 4" FORCE MAIN - 100 TO 400 GALLONS PER MINUTE**

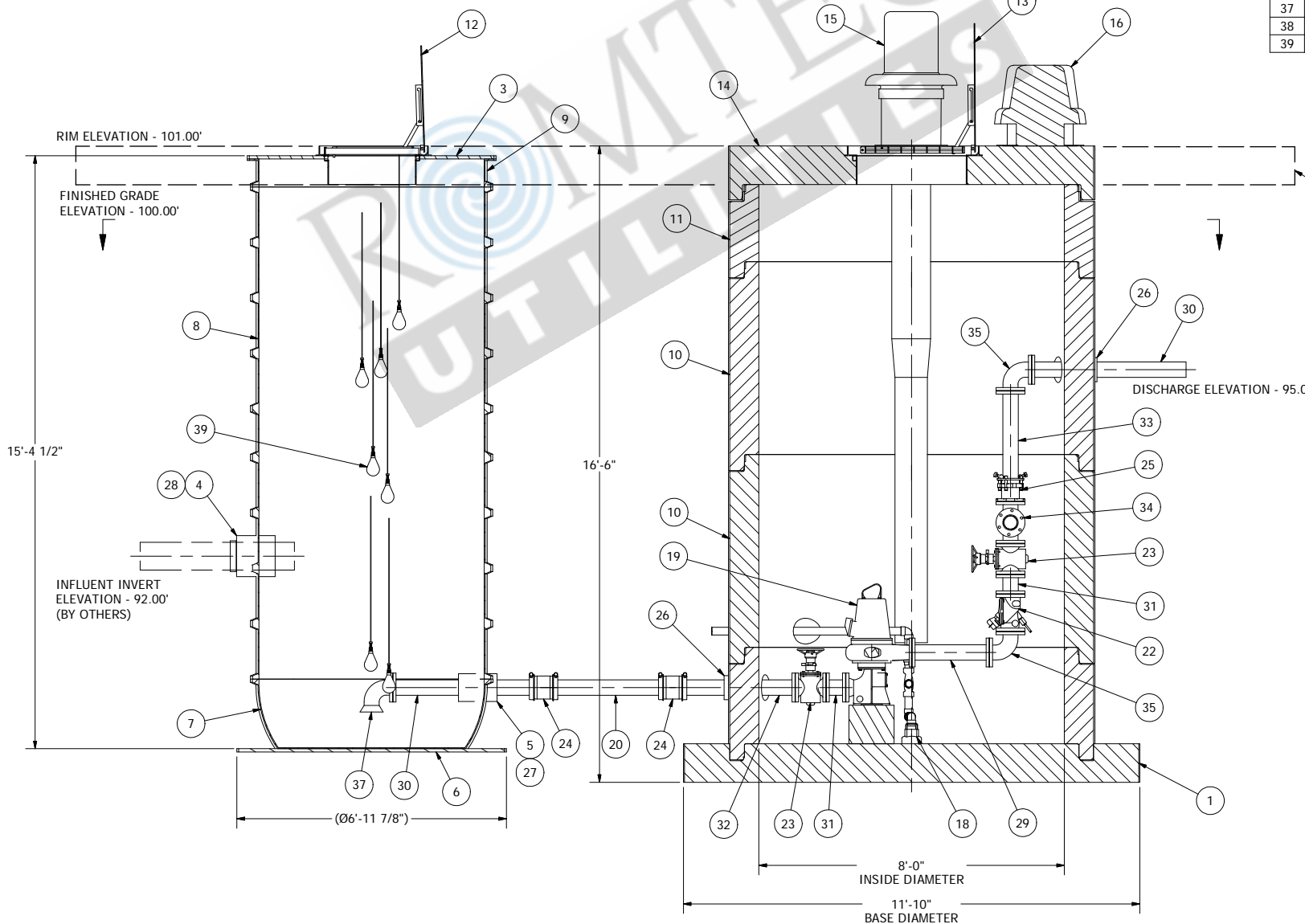
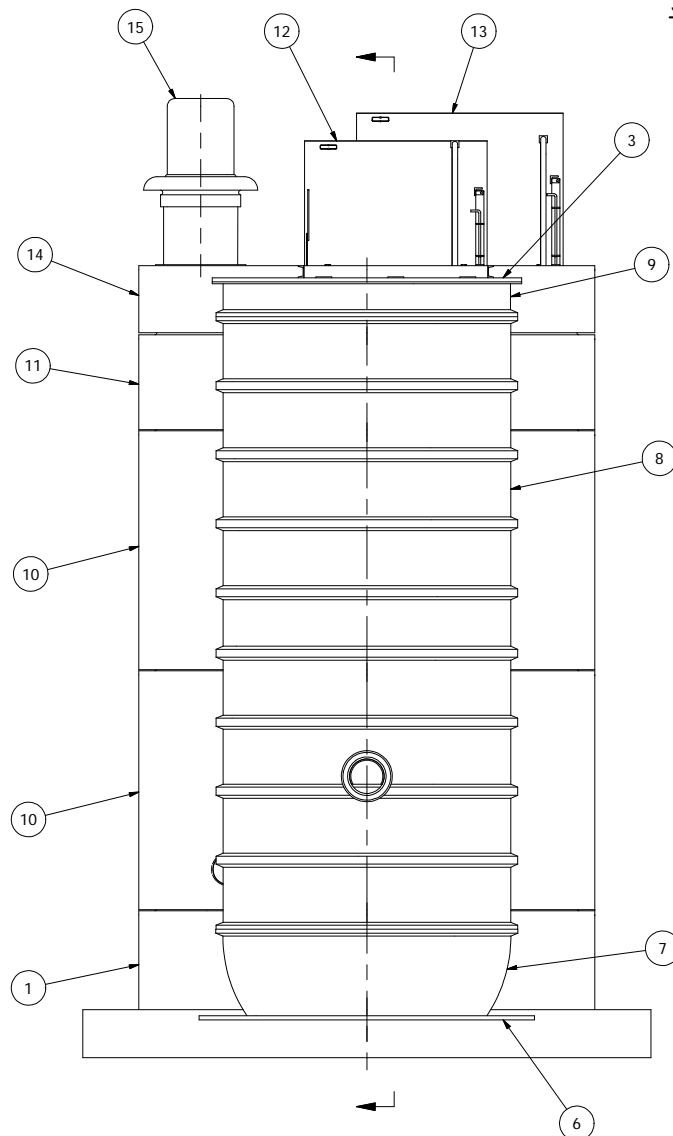

Parts List			
ITEM	QTY	STOCK NUMBER	DESCRIPTION
1	1	10-6482	BASE - WW - 8ft - FLAT BASE - 142in DIA
2	1	10-XXXX	CONCRETE RISER - PUMP SUPPORT
3	1	11-REF	TOP PLATE - 6ft
4	1	11-REF	PIPE SLEEVE - 12in
5	2	11-REF	PIPE SLEEVE - 8in
6	1	11-REF	FLANGE - ANTI FLOATATION
7	1	11-REF	BASE - TRUNCATED - 6ft X 60in
8	1	11-REF	BARREL - 6ft
9	1	11-REF	BARREL - TOP FLANGE - 6ft
10	2	12-6574	BARREL - 8ft DIA X 2ft H
11	1	12-6577	BARREL - 8ft DIA X 2ft H
12	1	13-5352	HATCH - WW - 5ft PED - 54729 - 27 X 40
13	1	13-5361	HATCH - WW - 6ft PED - 54730 - 34 X 46
14	1	14-6483	TOP SLAB - WW - 8ft PED - DUPLEX
15	1	18-XXXX	INTAKE FAN
16	1	18-XXXX	EXHAUST FAN
17	2	25-XXXX	LADDER - 15ft
18	1	25-XXXX	SUMP PUMP ASSEMBLY
19	2	30-5500	7.4HP PUMPS
20	2	40-6560	PIPE - DI - 4in
21	4	41-6564	HANDWHEEL - 8in
22	2	41-6565	VALVE - SWING CHECK - 4in
23	4	41-6583	VALVE - PLUG - 4in - WITH OP NUT
24	4	42-6034	COUPLING - HYMAX 2000 - 4in
25	1	42-6073	COUPLING - ROMAC - RFCA - 4in FBEC
26	4	43-5186	KOR-N-SEAL - 8in CORE -1.70 THRU 4.80 PIPE
27	2	43-5414	LINK SEAL - 4in X 8in
28	1	43-6135	KOR-N-SEAL - 12in CORE - 8in PIPE
29	2	45-5046	SPOOL - FLG X FLG - 4in X 24in - DI
30	3	45-6509	SPOOL: 4" X 48" DI FLG X PE
31	4	45-6512	SPOOL: 4"X6" DI FLG X FLG
32	2	45-6541	SPOOL: 4" X 36" DI FLG X PE
33	1	45-XXXX	SPOOL - FLG X PE - 4in X 30in - DI
34	1	45-XXXX	SPOOL - FLG X FLG - 4in X 16.75in - DI
35	4	46-6520	ELBOW - DI - 4in - 90 DEG - FLG X FLG
36	1	46-6524	TEE - DI - 4in - FLG X FLG
37	2	46-XXXX	ELBOW - DI - 4in - 90 DEG - FLG X FLARE
38	25	47-6546	GASKET - FLANGE - 4in X 1/8in
39	7	60-6117	MECH SWCH ENM-10 CABLE 43'

REV	DESCRIPTION	DATE	BY	AM
1	COMPONENT DRAWING	03/31/09		

**COMPONENT DRAWING**

**ROMTEC UTILITIES**  
 18240 NORTH BANK ROAD  
 ROSEBURG, OREGON 97470  
 (541) 496-9678  
 FAX (541) 496-0804

ROMTEC Utilities, Inc.  
**SMALL FLOW WET / DRY SYSTEM**

SHEET  
**1 OF 1**  
 JOB NUMBER  
**RMTC 0000**

© 2009 ROMTEC INC. ALL RIGHTS RESERVED. THESE PLANS AND DRAWINGS MAY NOT BE REPRODUCED, ADAPTED, OR FURTHER DISTRIBUTED, AND NO COMPONENTS MAY BE CONSTRUCTED FROM THESE PLANS, WITHOUT WRITTEN PERMISSION OF ROMTEC, INC.

NOTE: ALL DIMENSIONS AND ELEVATIONS SHOWN ARE NOMINAL DIMENSIONS. IT IS THE RESPONSIBILITY OF THE ON-SITE CONTRACTOR OR ROMTEC UTILITIES CUSTOMER (NOT ROMTEC UTILITIES) TO VERIFY THE ACCURACY OF ANY CRITICAL DIMENSIONS OR ELEVATIONS PRIOR TO SETTING OR INSTALLING ANY EQUIPMENT.

**6' DIAMETER WET WELL  
 4" DISCHARGE PIPING  
 7.4HP PUMPS  
 8' DIA DRY WELL**

ALL MATERIALS SHOWN ON THIS SHEET WILL BE SUPPLIED BY ROMTEC UTILITIES AND DELIVERED TO THE SITE AFTER THE HOLE HAS BEEN EXCAVATED AND SHORED. THE CONTRACTOR SHALL SUPPLY A CRANE OF SUFFICIENT SIZE TO LOWER ALL THE CONCRETE PIECES INTO THE HOLE SAFELY. THE CONTRACTOR SHALL INSTALL THE WET WELL (AND VALVE VAULT AND METERING VAULT IF APPLICABLE). ROMTEC UTILITIES WILL PROVIDE A REPRESENTATIVE FOR TECHNICAL ASSISTANCE ON THE DAY OF INSTALLATION TO ANSWER ANY QUESTIONS THAT MAY ARISE. THE CONTRACTOR IS RESPONSIBLE FOR ALL PLUMBING AND ELECTRICAL CONNECTIONS AND INSTALLATION. ITEMS NOTED AS "BY OTHERS" WILL BE PROVIDED AND INSTALLED BY THE CONTRACTOR. ROMTEC UTILITIES WILL NOT INSTALL ANY OF THE COMPONENTS SHOWN ON THIS PAGE.